

DFD2-Heath instructions.

After completing assembly, carefully inspect all of your solder connections, and the polarity of the diodes, voltage regulator, the electrolytic capacitor, and the IC's.

Adjust the contrast control fully counter-clockwise. Apply power from 8 to 18VDC. You should see some frequency displayed. Adjust the contrast control for the desired effect.













The top zero ohm jumper selects 100Hz resolution (jumper off) or 10Hz resolution (jumper on)

The bottom zero ohm jumper selects display format (where USB is used as an example of the operating mode display):

10 Hz resolution: 12.345.67MHz USB (jumper off) or 12.345.670 USB (jumper on)

100Hz resolution: 12.345.6 MHz USB (jumper off) or 12.345.600 USB (jumper on)

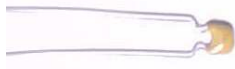
PARTS LIST

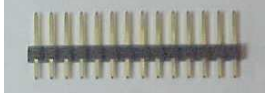
D1, D2, D3, D4, D5, D6	1N4148		U1, U2, U3	74HC4046	
R1	100ohms Brown-black-brown		U4	74HC153	
R2, R3	1000 ohms brown-black-red		U5	PIC16C71 Labeled according To the model DFD2	
			U6	78L05 Voltage regulator	
R4	10K trimpot contrast control adjust fully CCW		U7	20MHz TCXO	
	25 Turn trimpot value may vary		H1	2 pin header 2 Pin jumper	
C1, C2, C3 C4, C5, C6 C7, C8, C11	.1uF C1, 4 and 6 Mislabeled on schematic		J1	Female connector	
C12	10uF		P1	Male connector	

Use pins 1-14 of the display module. If 16 pins are available, last two are not used. Backlit option is powered according to supplemental instructions included.

DFD2 assembly instructions.

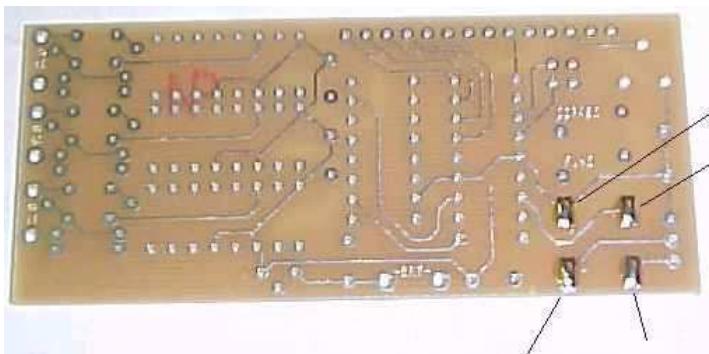

Begin by placing solder globs on the four rectangular pads for the surface mount TCXO.

If I pre-installed the TCXO, I could not test it. If unit displays only 8 black squares then check and reflow the solder on its four corners.

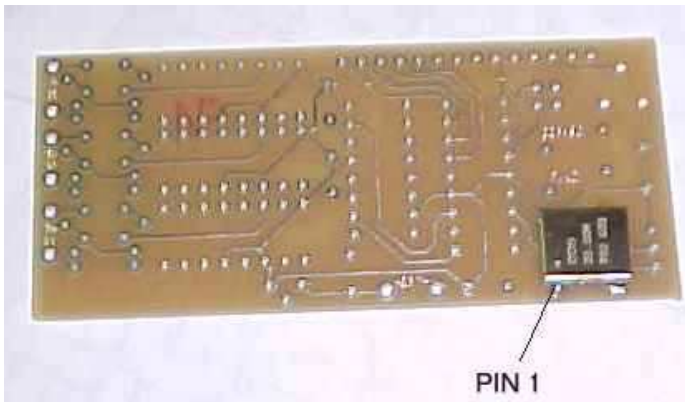

Carefully Position the TCXO with pin 1 as shown and remelt the solder globs while pushing down on that side of the device until all four pads of the TCXO are soldered. You can check by looking at the edge view to verify that solder has flowed onto the TCXO terminals. If later the unit shows only 8 black squares on the display it may be because one or more of these terminals did not properly reflow solder.

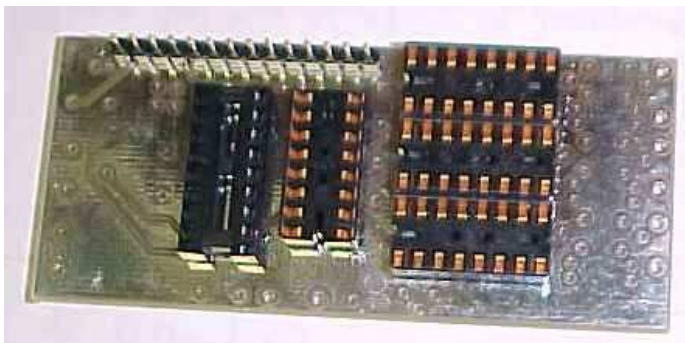

Next mount the IC sockets and display header.

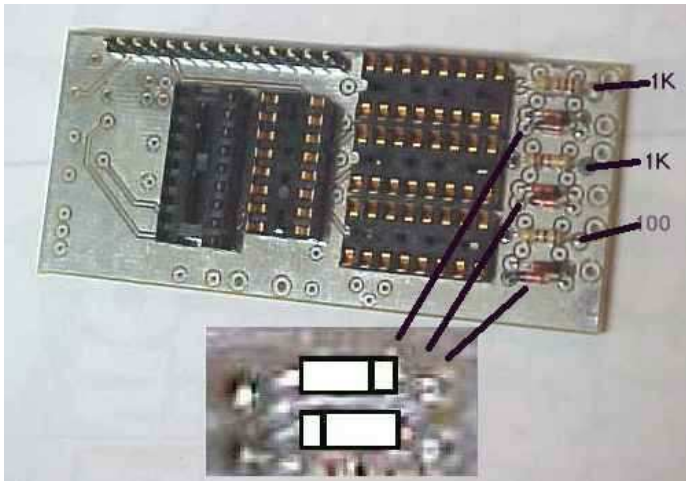

Next install and solder the two 1K and the 100 ohm resistors and the six back to back diodes.

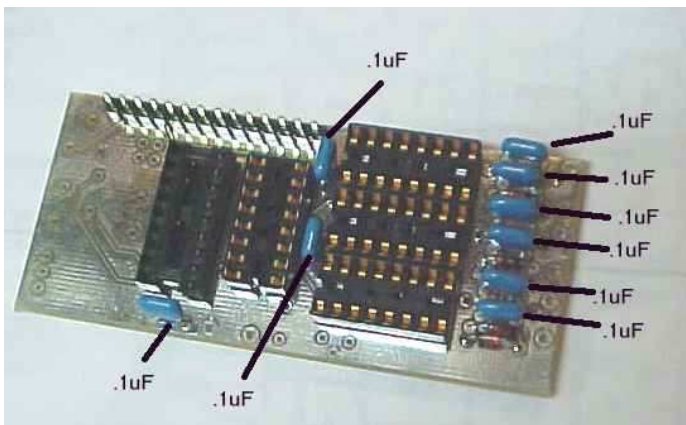

Then install and solder 9 each .1 uF capacitors **Caps can be blue or brown.**

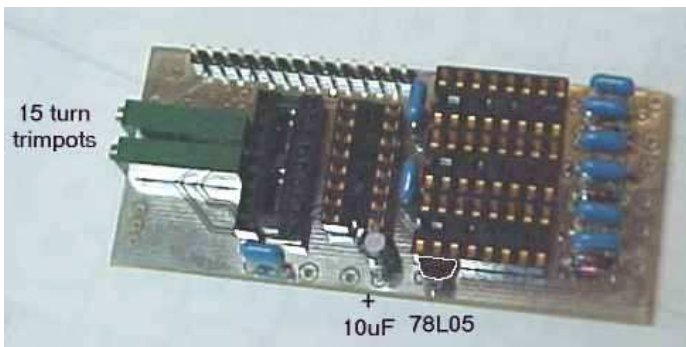

Next install the 78L05 voltage regulator, the 10uF electrolytic. **The two 15 turn trim pots are not used or included.**

+ **Terminal of 10uF electrolytic in hole closest to edge of PCB. Flat side of 78L05 toward IC sockets.**

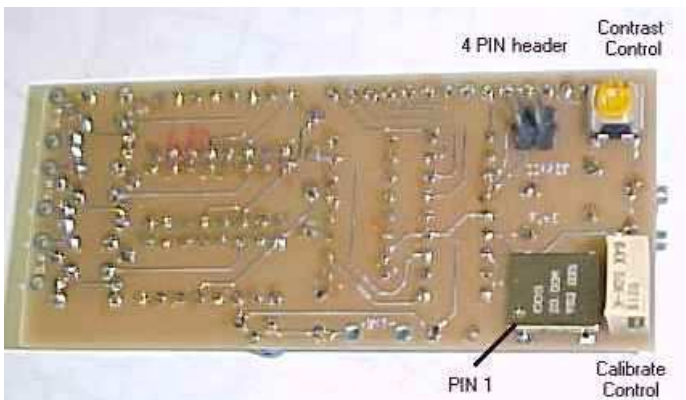

On the back side of the PCB install and solder the 10K contrast control (**adjust it fully CCW**) and the 25K calibration control.

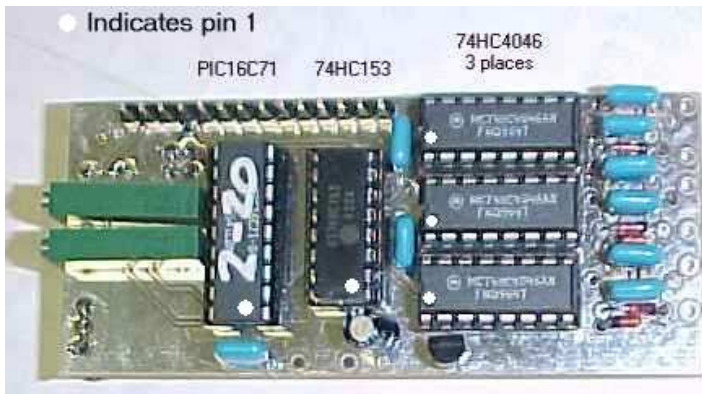

Next, Install the ICs.

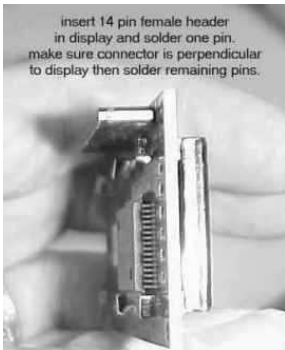

Mount the 14 pin female header on the display module

soldering only one pin.

Then verify the connector is at a right angle to the module, remelting the soldered pin and adjusting the connector if necessary.

Then solder the remaining pins.

Plug the module into the DFD2 PCB.

At this point you can plug the counter board into the module and power them with a 9 volt battery.

You should see something displayed.

What you see at this point is not important as some inputs are still floating until final assembly in your enclosure.

If only 8 black squares appear, either the TCXO has not been soldered on all 4 points or there is a solder problem on the circuits between the 18 pin chip and the display connector, or on the display module connector.

CALIBRATION

- There are many ways to calibrate a frequency counter depending on available test equipment.
- The simplest is to zero beat a signal generator against WWV (receiver bfo off) while measuring the generators frequency with the counter.
 - Adjust the 25 turn trimpot on the back of the PCB to obtain the WWV frequency (20 MHz) on the counters display.
 - Or listen to TCXO on receiver while zero beating it to WWV on 20MHz.
- Any other KNOWN frequency can also be used. Broadcast band AM stations are usually very accurate.

Installation

It is possible to overdrive the inputs causing erratic frequencies to be displayed. A 10K trimpot can be used to set the levels going into the DFD2.

the levels should be set only slightly greater than required for a stable display. Set the BFO input first, then the VFO and finally the HFO (usually on 10mtr band).

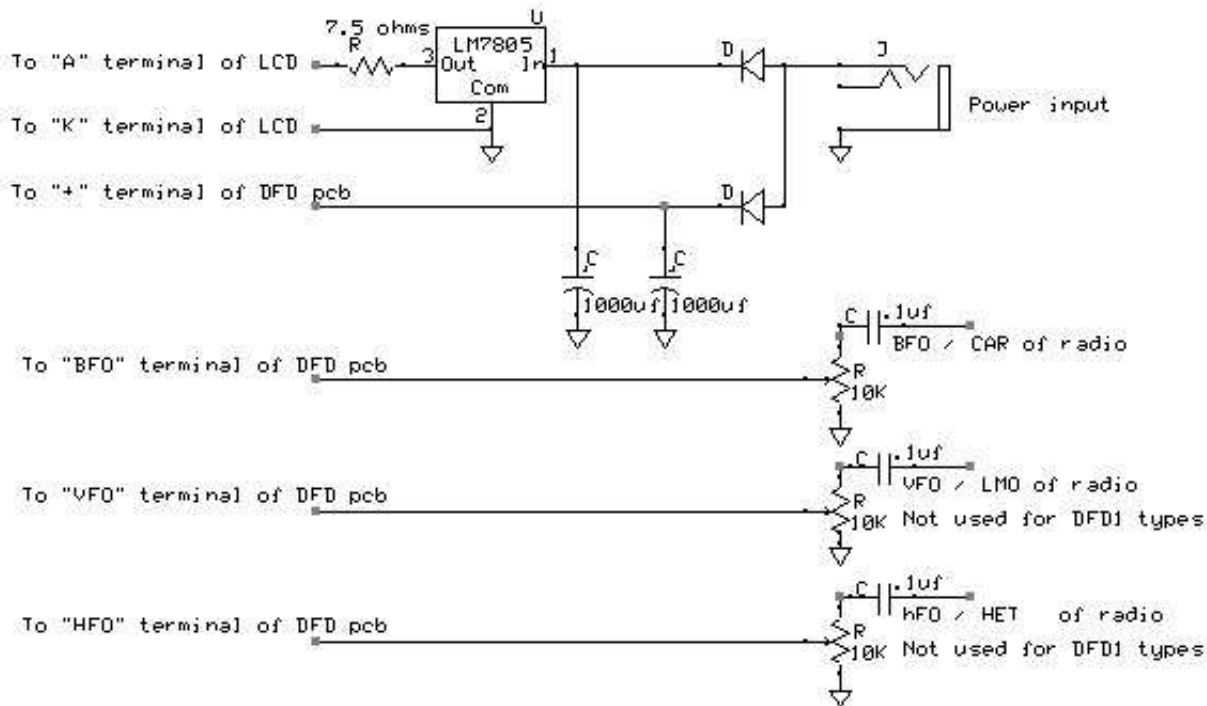

Power Conditioning module for DFD1 and DFD2 applications

This is the power conditioning module supplied as part of the plug-n-play fully assembled digital dials. Something similar is recommended for DFD2 applications to provide level controls.

Only one input is required for a DFD1.

The 7805 part is to power a backlit display option.

For additional installation hints see

<http://www.aade.com/applications2/app2.html>

Digital Frequency Display 2

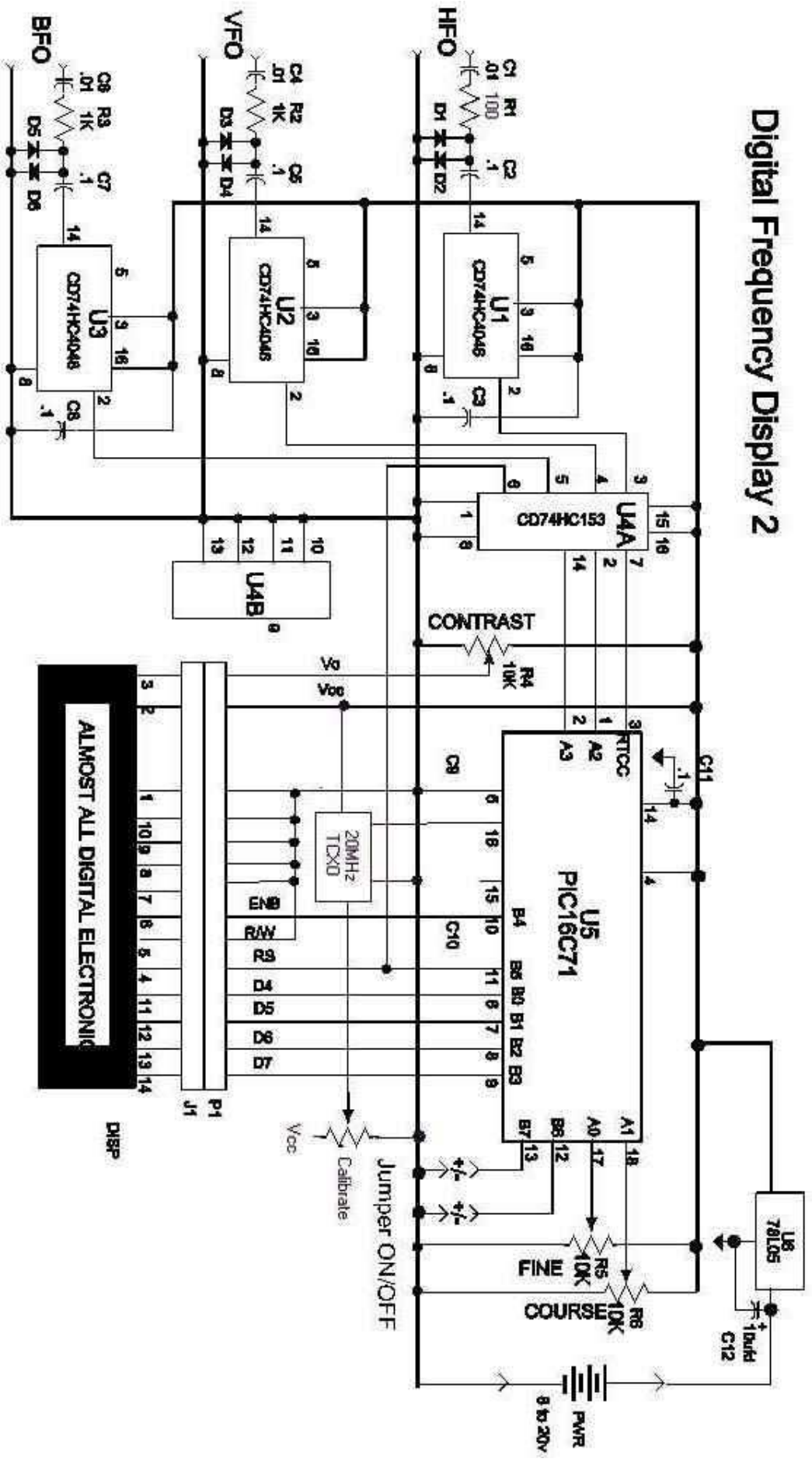

Heathkit SB and HW series

You can use the hardwire connections shown below or, if a vacuum tube radio, the Universal Tube Shield Interface.

For details see the web at

http://www.aade.com/Universal/a_universal_interface_for_tube_t.htm

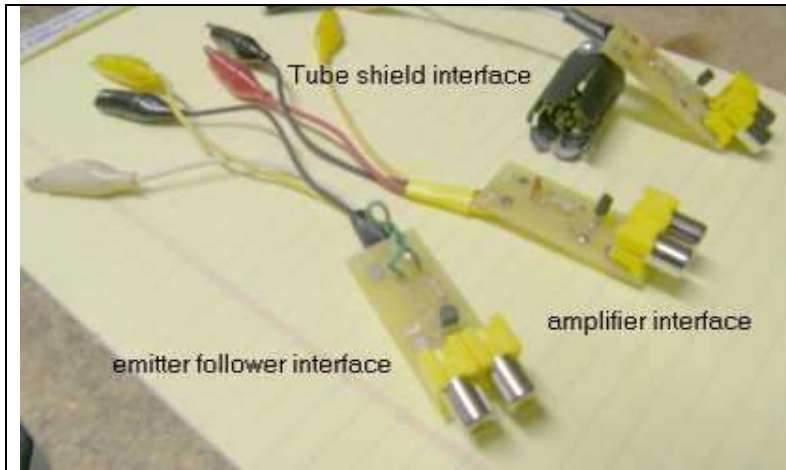

BFO tube shield over the carrier osc tube, (typically V16)

PMO tube shield over PMO buffer (typically V20)

HFO tube shield over Xtal osc tube (typically V19)

Power

9-18VDC or 6.3 to 12VAC (center conductor positive, shell ground)

IMPORTANT: POWER SOURCE SHOULD BE OFF BEFORE CONNECTING TO DIGITAL DISPLAY OR IT COULD BE SHORTED

Heathkit installation instructions.

These are from the SB-650 manual but should be directly applicable to the DFD2-301 (kit) or C-Heath (assembled) displays

INSTALLATION

The installation of the Frequency Display requires that your equipment (receiver or transceiver) furnishes three signals. These are the outputs of the HFO (high frequency oscillator), LMO/VFO (linear master oscillator/variable frequency oscillator), and BFO (beat frequency oscillator). This section of the manual presents the steps necessary to provide these three signals from Heath 5-band transceivers of the SB and HW (SB-100, HW-100, etc.), series and from amateur receivers of the SB series. No instructions for other makes of equipment are available.

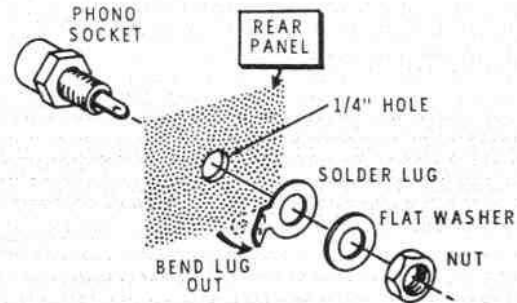

Figure 3-1

Three unused phono sockets must be available on the rear panel of your receiving equipment. If they are not, they must be installed. Your kit contains three phono sockets (with mounting hardware) for this purpose. Figure 3-1 is the socket mounting detail. DO NOT drill any holes until you have carefully read the "Installation" instructions for your equipment.

Figures 3-2 and 3-3 show two examples of where to locate additional phono sockets. Figure 3-2 shows an SB-102 transceiver. The original two spare phono sockets (spare A and spare B) are used. The ground terminal was moved and its original mounting hole was drilled out to provide a location for the third phono socket. Figure 3-3 shows where three phono sockets were added to an SB-301 receiver.

Before deciding upon the location for the mounting holes, be sure no cabinet lips, interior mounted parts, or other interference will exist. Select the socket locations to retain rear panel symmetry. Use a center punch to mark the centers of the 1/4" holes to be drilled.

Install the required number of phono sockets on the rear panel of your receiver or transceiver. Then select the appropriate following section and perform the indicated steps to connect the three required signals to the sockets. Upon completion, proceed to "Initial Tests" on Page 39.

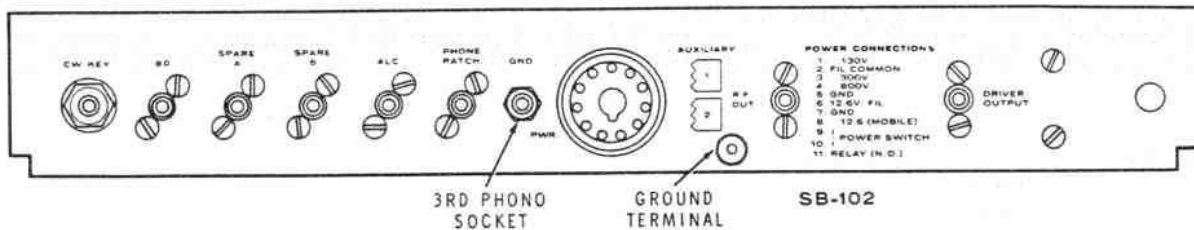

Figure 3-2

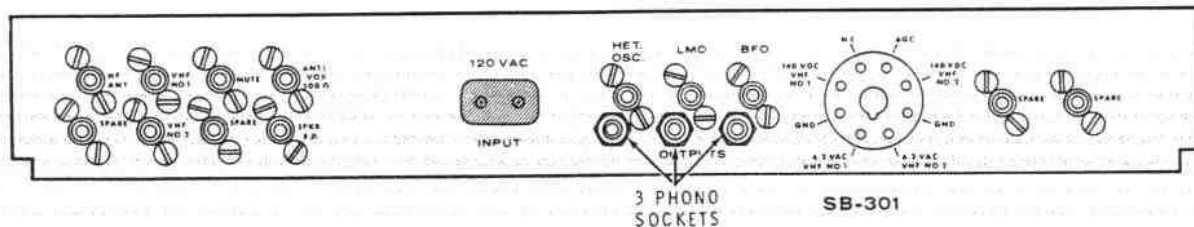

Figure 3-3

TRANSCEIVERS

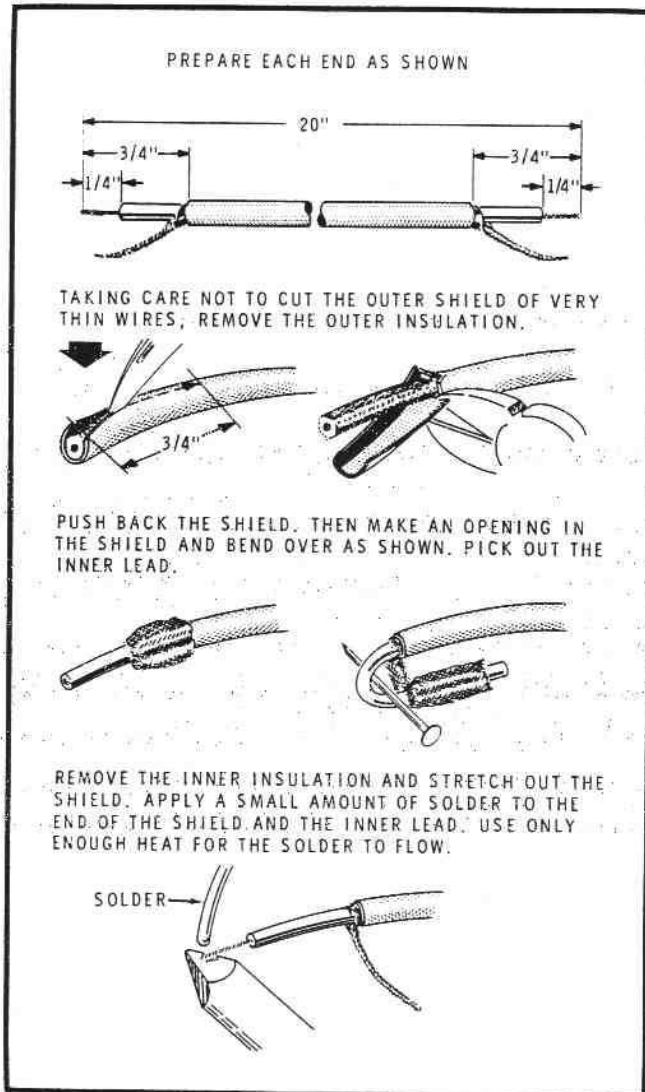

Figure 3-4

BFO MODIFICATION (SB and HW Series)

Refer to Figure 3-4 for the following steps.

- () Cut a 20" length of RG-174 coaxial cable and remove 3/4" outer insulation from each end.
- () At each end of the coaxial cable, pull the inner insulation and center conductor from the outer shield.

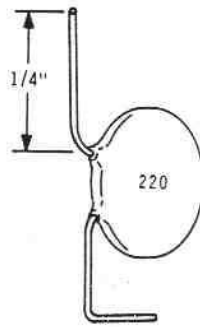

Figure 3-5

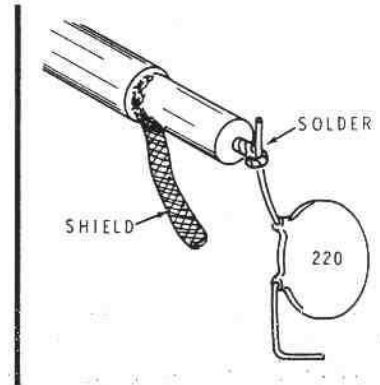

Figure 3-6

- () Remove 1/4" of insulation from the center conductor and trim off any stray strands of wire from the shield braid.
- () Refer to Figure 3-5 and cut the leads of a 220 pF capacitor to 1/4". Form the leads as shown.
- () Refer to Figure 3-6 and connect one end of the cable center conductor to the 220 pF capacitor (S-1).

Refer to Figure 3-7 for the following steps:

- () With the under side of the chassis positioned as shown, push the free end of the coaxial cable under the switch shaft and through grommet CB until about 3" remains over the modulator circuit board.
- () Connect the foot of the 220 pF capacitor to the foil at point A (S-1).
- () Connect the shield braid to the foil at Point B (S-1).
- () Pull any excess cable through grommet CB, but do not place any strain on the capacitor or braid connections.
- () Position the coaxial cable as shown and connect the center conductor at the free end to the center lug of an unused phono socket (S-1). Connect the braid to the ground lug of the same socket (S-1).
- () On the outside of the rear panel, mark this socket "BFO."

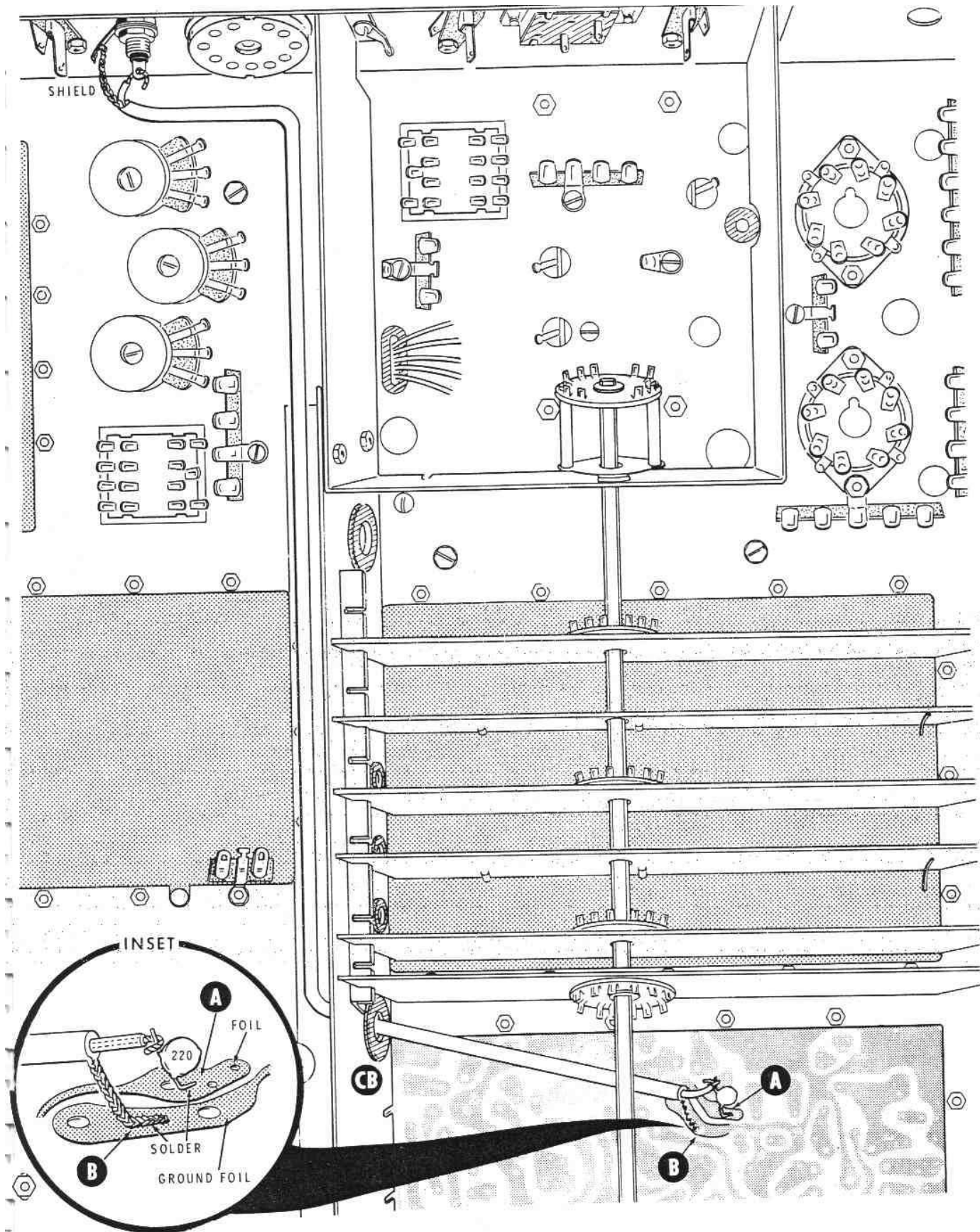

Figure 3-7

HFO MODIFICATIONS (SB and HW Series)

Refer to Figure 3-8 for the following steps (HW-#series illustrated).

- () Use a knife with a sharp point to break the foil near pin 8 of V19. A narrow strip of foil 1/32" to 1/16" wide should be cut and removed.
- () Cut the leads of a 51 Ω , 5% resistor (green, brown, black, gold) resistor to 3/8" and form them as shown in the inset drawing.
- () Solder the foot of one resistor lead to the foil at point C. Solder the other foot to the ground foil at point D.
- () Cut a length of RG-174 coaxial cable (small) long enough to reach from point C in the preceding step to an unused phono socket, plus 1" (so the connections will not be under stress).
- () Remove 3/4" of outer insulation from each end of the cable, pull the inner conductor out of the shield as before and remove 1/4" of insulation from the ends of the center conductor.
- () At one end of the cable, connect the center conductor to point C (S-1) and the shield braid to point D (S-1).
- () At the other end of the cable, connect the center conductor to the center lug of the selected phono socket (S-1). Connect the shield braid to the ground lug of the same socket (S-1).
- () On the outside of the rear panel, mark this socket "HFO."

LMO MODIFICATION (SB Series Only).

Refer to Figure 3-9 (fold-out from Page 35) for the following steps.

- () Cut a length of RG-174 coaxial cable (small) which will reach from foil pad H on the bandpass circuit board to an unused phono socket, plus 1".

- () Prepare the ends of the cable as before. See Figure 3-4.
- () At one end of the cable, bend a small foot on the center conductor and solder it to foil pad H. Solder the shield braid of the cable to the hole in the foil at point E.
- () At the free end of the coaxial cable, connect the center conductor to the center lug of the selected phono socket (S-1). Connect the shield braid to the ground lug of the same socket (S-1).
- () On the outside of the rear panel, mark this socket "LMO."

VFO MODIFICATION (HW Series 5-Band Transceivers Only)

Refer to Figure 3-10 (fold-out from Page 35) for the following steps.

- () Cut a length of RG-174 coaxial cable (small) which will reach from foil pad G on the bandpass circuit board to an unused phono socket, plus 1".
- () Prepare the ends of the cable as before. See Figure 3-4.
- () At one end of the cable, bend a small foot on the center conductor and solder it to foil pad G. Solder the shield braid of the cable to the hole in the foil at J.
- () At the free end of the coaxial cable, connect the center conductor to the center lug of the selected phono socket (S-1). Connect the shield braid to the ground lug of the same socket (S-1).
- () On the outside of the rear panel, mark this socket "LMO."

IMPORTANT: AFTER you have completed the modification of your equipment for the Frequency Display, and BEFORE you start the "Initial Tests," refer to the manual for your equipment and perform the alignment instructions for the HFO (high frequency oscillator) circuits. Also, be sure your equipment is operating normally on all bands before starting the "Initial Tests."

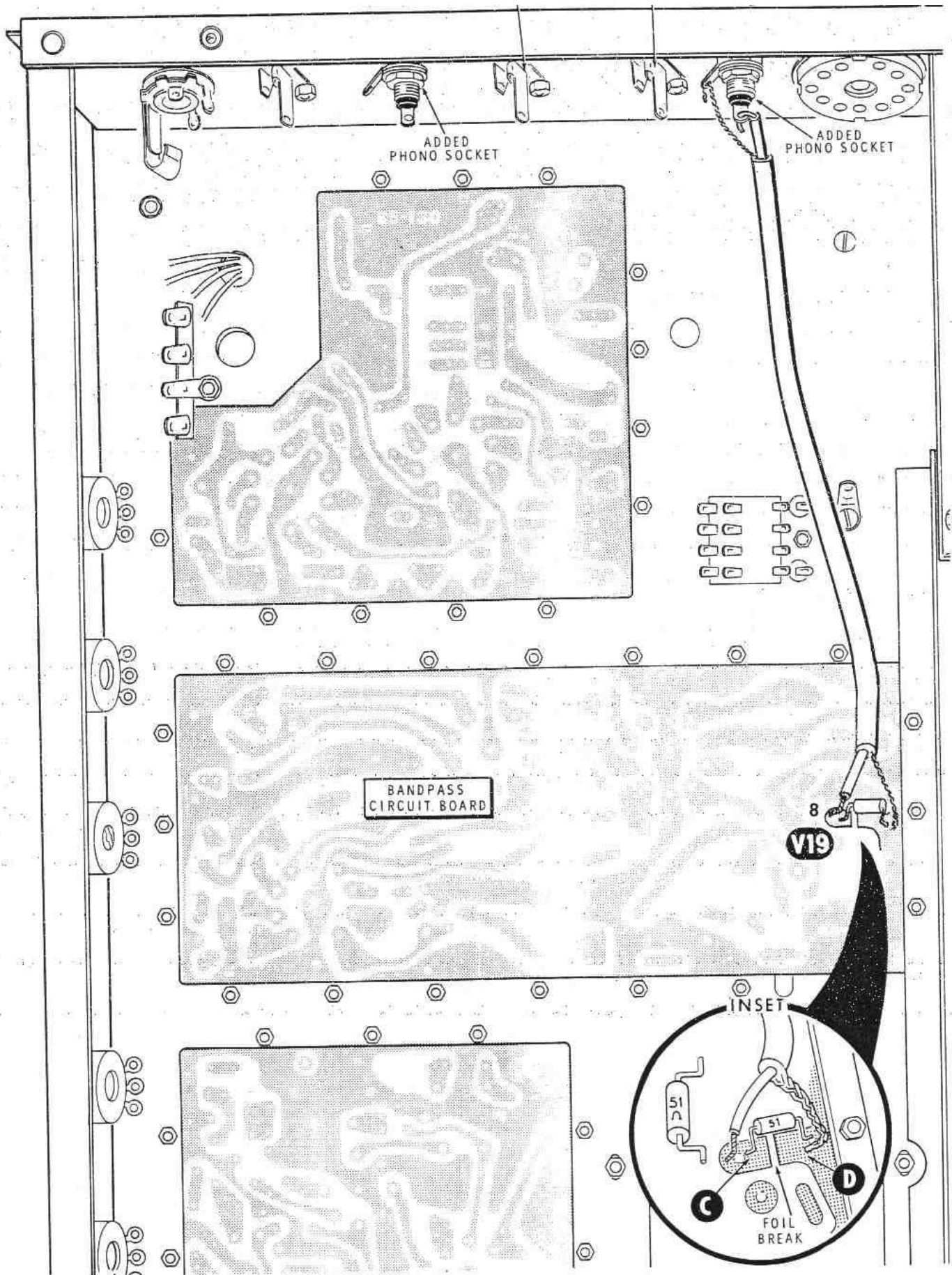
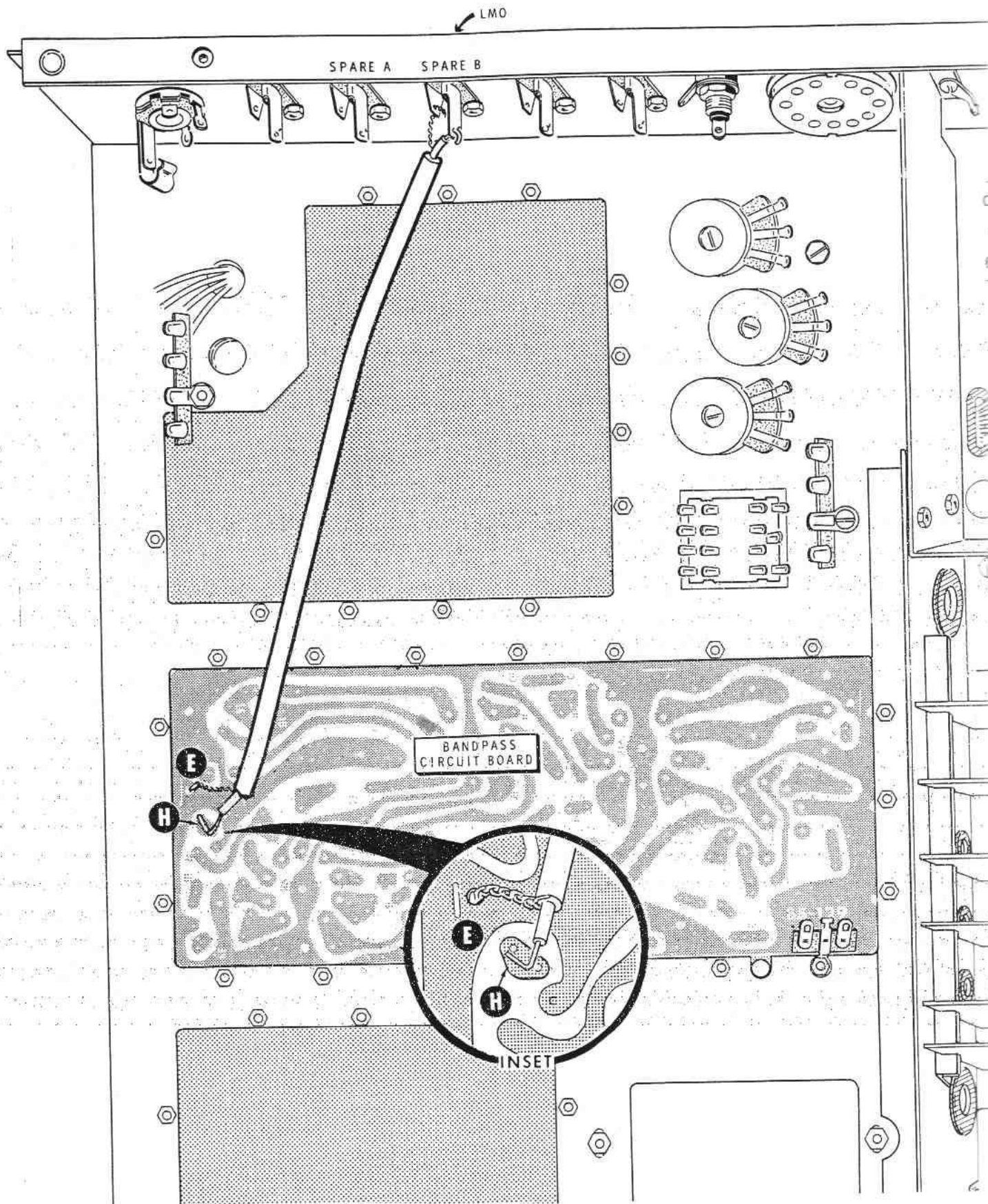

Figure 3-8
(HW-SERIES)



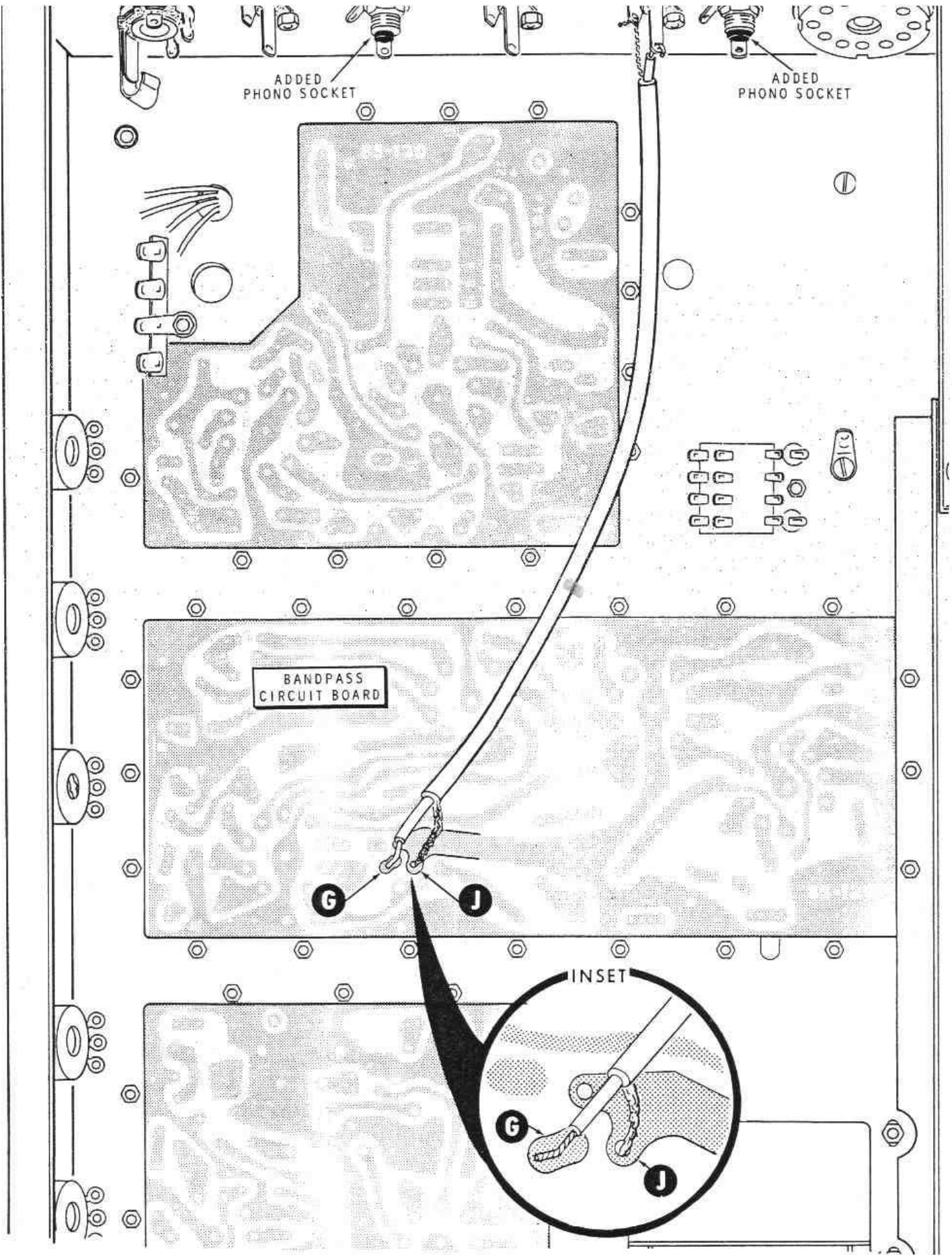

FIGURE 3-10
(HW-SERIES)

RECEIVERS

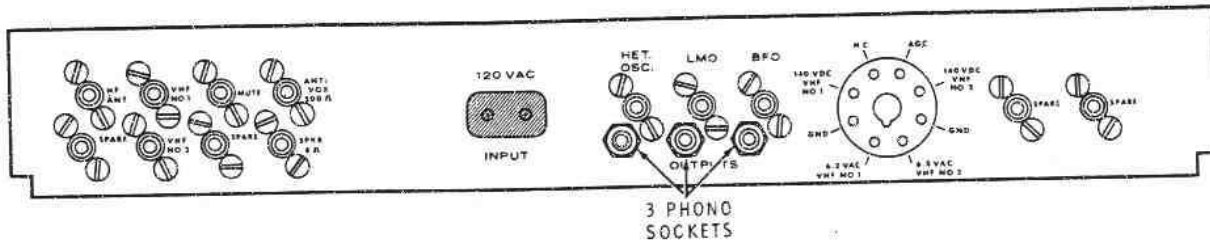

Figure 3-11

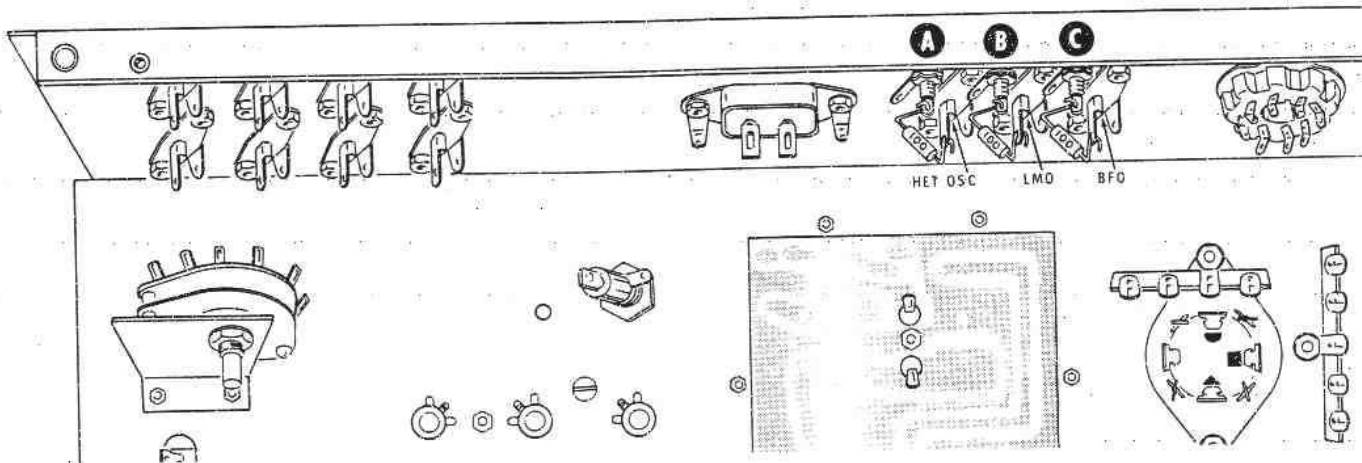

Figure 3-12

NOTE: If the following Receivers (SB-300, SB-301, SB-303) are used in the transceive mode with the SB-400 or SB-401 Transmitters, the RF choke furnished must be installed in the transmitter. Refer to Figure 3-13 (Pictorial 10 in the SB-400 Manual, or Pictorial 4-2 in the SB-401 Manual).

- () Bend each lead of an RF choke (#45-76) toward the slot in the choke winding form.
- () Connect the RF choke between lugs 1 and 2 of the terminal strip (S-2). It may be necessary to melt the existing solder in the lugs before the choke leads can be inserted.
- () Cut off the excess lead lengths, and check carefully to see that all connections to lugs 1 and 2 remain well soldered.

SB-300 AND SB-301

- () Refer to Figure 3-11 and install three phono sockets at the locations shown. Refer to Figure 3-1 for the hardware mounting detail.
- () On the inside of the rear panel, refer to Figure 3-12 and connect a 100 Ω (brown-black-brown) resistor from the center lug of the HET OSC socket (S-1) to the center lug of socket A (S-1).
- () Connect a 100 Ω (brown-black-brown) resistor from the center lug of the LMO socket (S-1) to the center lug of socket B (S-1).
- () Connect a 100 Ω (brown-black-brown) resistor from the center lug of the BFO socket (S-1) to the center lug of socket C (S-1).

IMPORTANT: AFTER you have completed the modification of your equipment for the Frequency Display and BEFORE you start the "Initial Tests," refer to the manual for your equipment and perform the alignment instructions for the HFO (high frequency oscillator) circuits. Also, be sure your equipment is operating normally on all bands before starting the "Initial Tests."



- I used this with a HW-101. Here are the particulars:
 - All connections are made at the cathodes of the various oscillator tubes.
 - All connections are made through a 27pF cap and RG-174 coax. 27 pf was found to provide adequate coupling without loading any stage.
 - HFO connection at pin 7 of V11
 - VFO connection at pin 7 of V12
 - BFO connection at pin 9 of V13
 - Bypass (Jumper out) the input .01 and the 1 K res on the HFO input ckt of the counter if it will not count above 15 meters.
 - Keep cables as short as possible.

Rodger



- I received the kit and burned the midnight oil to get the thing working. Which it does. I would like to add a possible aid for anyone else doing this 301 into HW-101 conversion. The BFO connection suggestion on your site did not work for me. Instead I used the junction of R17 and CR2 before the resistance of R17 effects the line level. Instead of using the cathode of the tube at the end of that line. It now works perfectly as you can see.

Jake

- **SB-102**([using DFD2-Heath](#))

- Hello Neil! I received the [DFD2](#) kit, programmed for a Heath SB-301,
- in the mail yesterday to be used on my Heath SB-102. Foresaking all
- other household chores, I assembled the kit. It works like a champ.
- For other person's info, these are the connections I made to the Heath
- SB-102. For the BFO connection, I used Pin 9 on Tube V-13C which is the
- product Detector. For the VFO, I used Pin 7 on Tube V-12A which is the
- Second Receiver Mixer. These can easily be accessed from the bottom of
- the Circuit board. The HFO is a little harder to access. I used Pin 7
- on Tube V-11 which is the First Receiver Mixer. It is almost impossible
- to access from the bottom, but the way the tube sockets are constructed,
- it is easy to solder the lead from the top on the tube socket. These
- are all Cathode connections, which you recommended. Naturally I used
- shielded cable for all connections.
- I used the Phono connectors on the back of the Chassis. There is Spare
- A and Spare B already, I unhooked the wire from the ALC connector (Since
- I don't plan to use an Amplifier) and used that one for the third
- connection.
- Bucky
- KB5DRZ

- **Unique SB102** on [Youtube](#) by KS1U. example of DFD2-Heath built in.

